

ADAC GT Masters Oschersleben ADAC Formula 4

DECISION

The Stewards, after having received a report from the Technical Delegate, which is attached and self explanatory concerning

Competition No., Driver: **10, LAPPALAINEN, Konsta** (License No. 32489194)
Competitor: **KIC Driving Academy** (License No. 50033250)

at: **Driver entered the pit lane without wearing gloves** Time: **12:21**, Session: **Before 1st Race**

After hearing Mr. Lappalainen
and after having examined the following evidence

- | | | |
|--|--|----------------------------------|
| <input type="checkbox"/> Video submitted | <input checked="" type="checkbox"/> Technical Report | <input type="checkbox"/> Photos |
| <input type="checkbox"/> Time Keeping Report | <input type="checkbox"/> see documents attached | <input type="checkbox"/> Witness |

have considered the following matter and came to the following

DECISION

Warning

In accordance with Art. 12.2.3.b ISC, the decision set out above will be suspended in case of an appeal.

FINDINGS

Reason: The driver of car # 10 entered the pitlane without wearing gloves
Offence: ISG attachment L, capture 3.2

announced on **14.04.2018** at **14:45** hours The decision is sent with registered letter and acknowledgement of receipt

Achim LOTH

Carsten Ruscher

Denny Enick

- I herewith confirm having received a copy of the decision and being reminded of my right to appeal.
- I renounce on my right to appeal.

Oschersleben, 14.04.2018

Time: 14:35

KIC Driving Academy:

ADAC GT Masters Oschersleben ADAC Formula 4

DECISION

The Stewards, after having received a report from the Technical Delegate, which is attached and self explanatory concerning

Competition No., Driver: **28, WISHOFER, Mick** (License No. JA 2349)
Competitor: **US Racing - CHRS** (License No. BIF 1170373)

at: **Driver entered the pitlane without wearing gloves** Time: **12:20**, Session: **Before 1st Race**

After hearing Mr. Wishofer
and after having examined the following evidence

- | | | |
|---|--|----------------------------------|
| <input checked="" type="checkbox"/> Video submitted | <input checked="" type="checkbox"/> Technical Report | <input type="checkbox"/> Photos |
| <input type="checkbox"/> Time Keeping Report | <input type="checkbox"/> see documents attached | <input type="checkbox"/> Witness |

have considered the following matter and came to the following
DECISION

Warning

In accordance with Art. 12.2.3.b ISC, the decision set out above will be suspended in case of an appeal.

FINDINGS

Reason: The driver of car # 28 entered the pitlane without wearing gloves
Offence: ISG attachement L, capture 3.2.

announced on **14.04.2018** at **13:15** hours The decision is sent with registered letter and acknowledgement of receipt

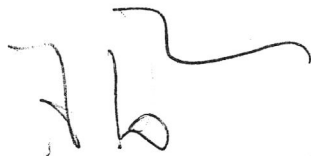

Achim LOTH

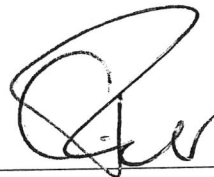

Carsten Ruscher



Denny Enick

- I herewith confirm having received a copy of the decision and being reminded of my right to appeal.
 I renounce on my right to appeal.

Oschersleben, 14.04.2018

Time: 13:24

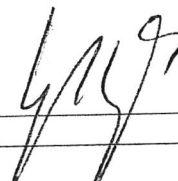
US Racing - CHRS: 

ADAC GT Masters Oschersleben ADAC Formula 4

DECISION

The Stewards, after having received a report from the Technical Delegate, which is attached and self explanatory concerning

Competitor: **KIC Driving Academy** (License No. 50033250)

at: **car # 10 ist not in compliance with the technical regulations** Time: **18:06**, Session: **After 2nd Race**

After hearing Mr. Suonsilia
and after having examined the following evidence

- | | | |
|--|--|--|
| <input type="checkbox"/> Video submitted | <input checked="" type="checkbox"/> Technical Report | <input checked="" type="checkbox"/> Photos |
| <input type="checkbox"/> Time Keeping Report | <input type="checkbox"/> see documents attached | <input checked="" type="checkbox"/> Witness Mr. Bartsch (Techn. Delegate) |

have considered the following matter and came to the following

DECISION

Disqualification from Race 2

In accordance with Art. 12.2.3.b ISC, the decision set out above will be suspended in case of an appeal.

FINDINGS

Reason: The minimum thickness of the front camber setting must be 1.0 mm, at least one item must be installed on each of the front wheel corners. No camber shim was installed at both front wheel corners. Approved by the Competitor.

Offence: Car # 10 is not in compliance with the technical regulations.

announced on **14.04.2018** at **18:50** hours

The decision is sent with registered letter and acknowledgement of receipt

Achim LOTH

Carsten Ruscher

Denny Enick

I herewith confirm having received a copy of the decision and being reminded of my right to appeal.

I renounce on my right to appeal.

Oschersleben, 14.04.2018

Time: 18.53

KIC Driving Academy:

ADAC Formula 4
ADAC GT Masters Oschersleben

DMSB

Event: ADAC GT Masters Oschersleben
Check Time: After 2nd Race
Time: 14.04.2018 18:06:39
Report: **Technical report**

From: The Technical Delegate
To: The Stewards of the meeting

Team: **KIC Driving Academy**
Driver: **10 - LAPPALAINEN, Konsta**
Facts: **Not in compliance with the Technical Regulations**

The minimum thickness of the front camber setting must be 1.0 mm, at least one of the following items must be installed on each of the front wheel corners.

- 01 00 07 26A: Camber shim 1 mm
 - 01 00 07 26B: Camber shim 2 mm
- No camber shim is installed at both front wheel corners.

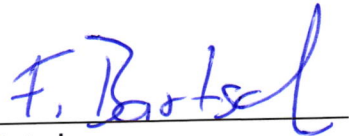

Florian Bartsch
Technical Delegate

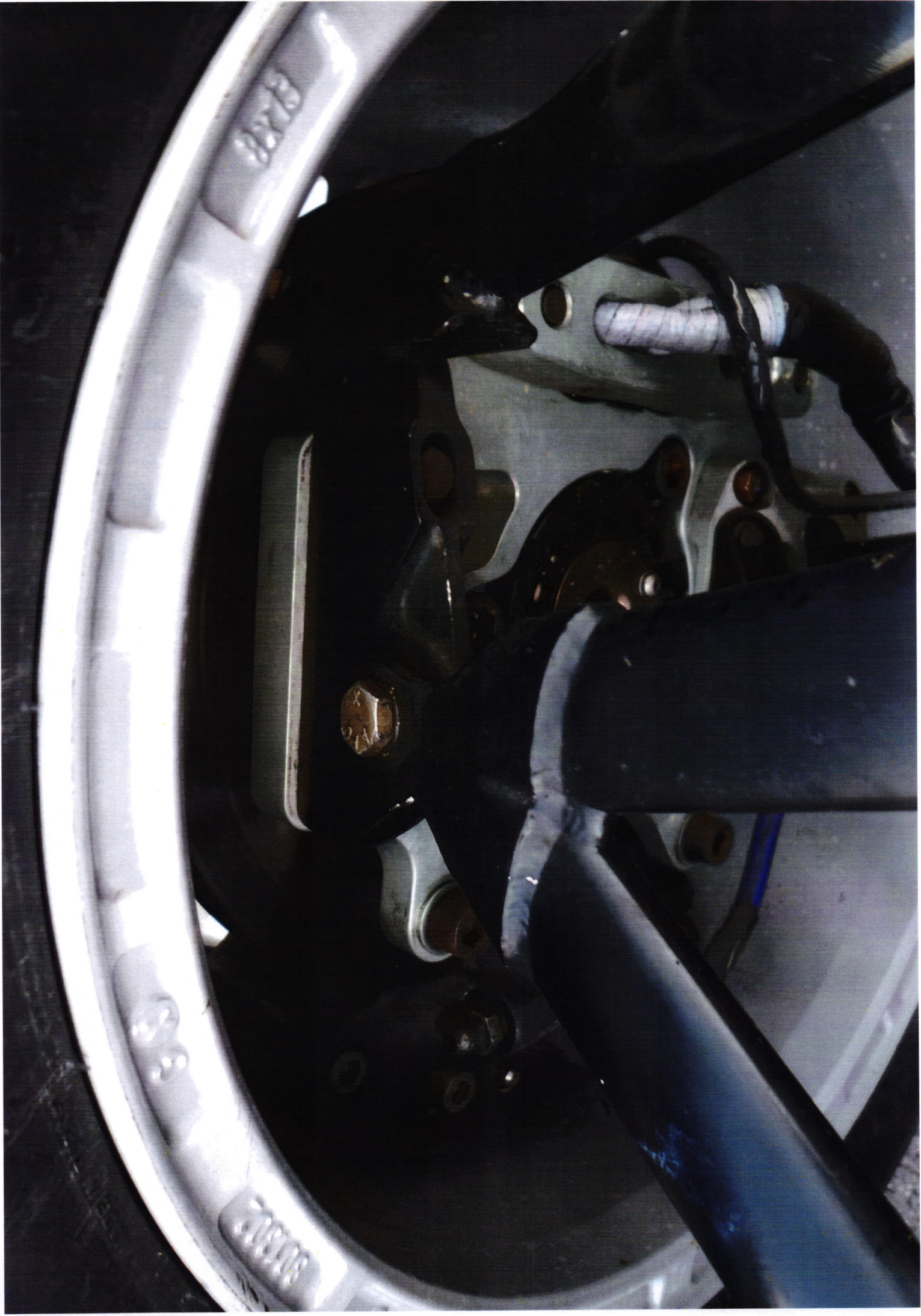

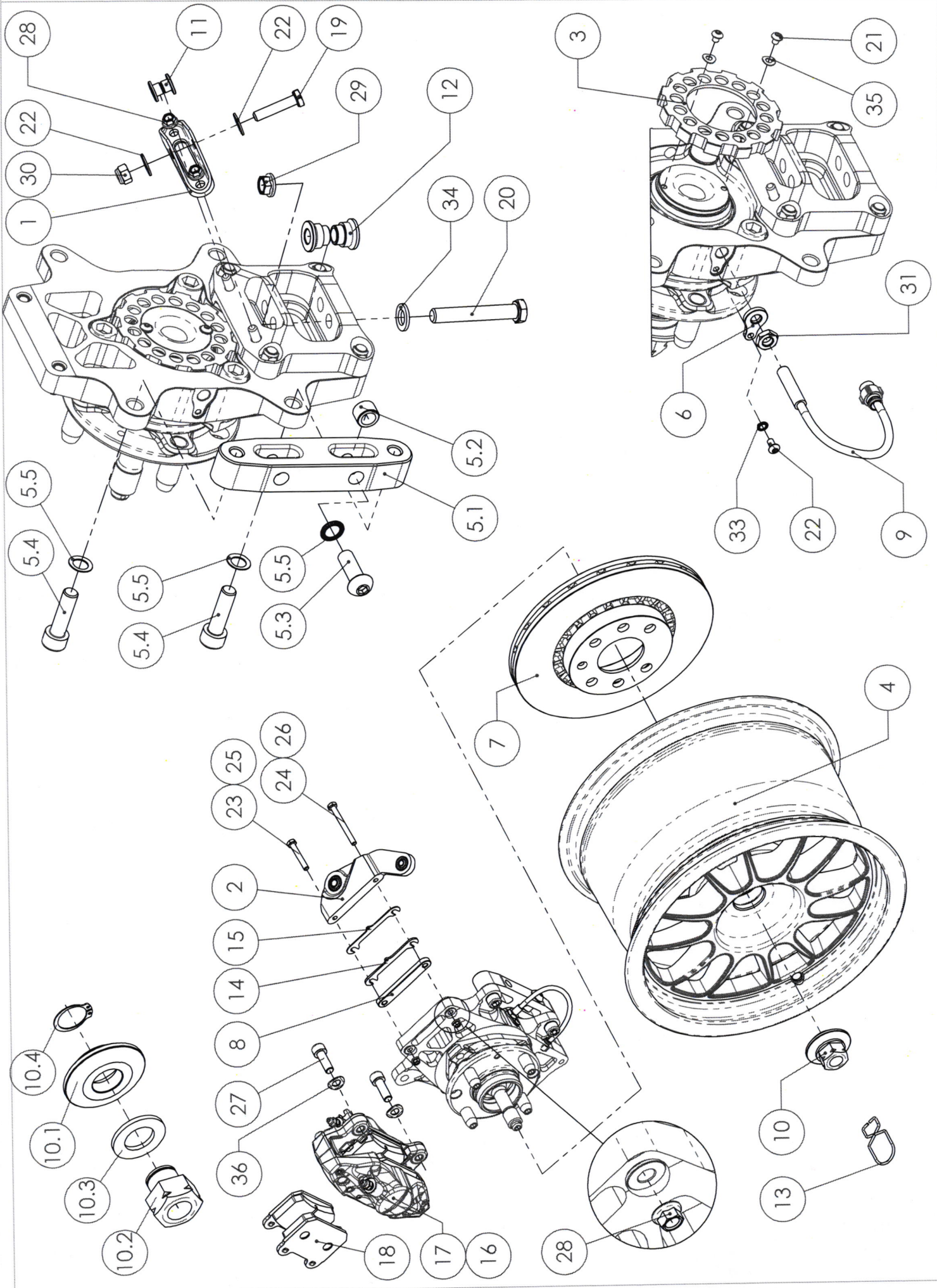

07A - FRONT UPRIGHT

Item	Part Number	Descrizione	Description	1	2	3
1	161407009	Attacco puntone	Pushrod bracket	x		
2	161407011	Ackerman	Ackerman	x		
3	161407013	Ruota fonica	Trigger wheel	x		
4	161407017	Cerchio 8"x13"	Wheel 8"x13"	x		
5	161507023	Asieme fissaggio cavo di ritenzione	Wheel tether bracket assy			
5.1	161507023001	Fissaggio cavo di ritenzione	Tether bracket	x		
5.2	181507014	Boccola	Bush	x		
5.3	UNI7380-M10X30	Vite TB	BH Bolt	x		
5.4	UNI5931-M10X35	Vite TC	CH Bolt	x		
5.5	RZS10	Rondella zigrinata	Safety washer			x
6	101007012	Supporto sensore velocità	Sensor bracket	x		
7	09552724	Disco Freno	Brake disc		x	
8	090907006	Spessore camber 6mm	Camber shim 6mm		x	
9	090907018	Sensore Velocità	Speed sensor	x		
10	090907034	Dado ruota completo DX	Rh wheel nut assy			
10.1	090907033001RH	Campanella dado ruota DX	Right wheel Nut bell	x		
10.2	010407033	Dado ruota DX	Rh wheel nut	x		
10.3	UNI6592-20	Rondella	Washer	x		
10.4	DIN471E21	Seeger	Seeger			x
11	080608010	Boccola	Bush	x		
12	080610006	Boccola ABWT 8	Bush	x		
13	010007018	Clip sicurezza	Safety spring	x		
14	01000726B	Spessore camber 2 mm	Camber shim 2mm		x	
15	01000726A	Spessore camber 1mm	Camber shim 1mm		x	
16	XA6L611	Pinza freno	Brake caliper	x		
17	XA6L612	Pinza freno	Brake caliper	x		
18	FDS1562	Pastiglie Freno (coppia)	Brake pads (Pair)		x	
19	AN4-11A	Vite NAS	NAS Bolt			x
20	AN6-22A	Vite NAS	NAS Bolt			x
21	UNI7380-M4X5	Vite TB	Bolt			x
22	UNI7380-M4X8	Vite TB	BH Bolt			x
23	UNI5737-M6X40	Vite TE cl 10.9	HE Bolt class 10.9		x	
24	UNI5737-M6X60	Vite TE cl 10.9	HE Bolt class 10.9		x	
25	UNI5737-M6X45	Vite TE cl 10.9	HE Bolt class 10.9		x	
26	UNI5737-M6X65	Vite TE cl 10.9	HE Bolt class 10.9		x	
27	UNI5931-M10X30	Vite TC	CH bolt			x
28	AST-06	K-Nut	K-Nut			x
29	AST-3/8	K-Nut	K-Nut			x
30	AN365-1/4X28	Dado autobloccante	Self locking nut			x
31	UNI5589-M8	Dado esagonale basso	Thin hex nut			x
22	AN960-1/4	Rondella AN 960 1/4	Washer AN 960 1/4			x
33	RZS4	Rondella zigrinata	Safety washer			x
34	UNI6592-10	Rondella stretta	Washer			x
35	UNI8840B-4	Rondella Ondulata	Crinkle washer			x
36	UNI8840B-10	Rondella Ondulata	Crinkle washer			x

- #7 09552724 Minimum thickness 17.0mm
- #8 090907006 Number and stack of shim is free, item may be removed down to a minimum thickness of 1mm
- #14 01000726B Number and stack of shim is free, item may be removed down to a minimum thickness of 1mm
- #15 01000726A Number and stack of shim is free, item may be removed down to a minimum thickness of 1mm
- #23 UNI5737-M6X40 May be replaced by item #25
- #24 UNI5737-M6X60 May be replaced by item #26
- #25 UNI5737-M6X45 May be replaced by item #23
- #26 UNI5737-M6X65 May be replaced by item #24

Reg.-No.: 83/18
Decision: 80



ADAC GT Masters Oschersleben
ADAC Formula 4

DECISION

The Stewards, after having received a report from the Race Director, which is attached and self explanatory concerning

Competition No., Driver: **06, COHEN, Ido** (License No. 2004)
Competitor: **ADAC Berlin-Brandenburg e.V.** (License No. BIC 1012474)

at: **Causing a collision with car # 13** Time: **20:05**, Session: **During 3rd Race**

After hearing Mr. Cohen, Di Comberti
and after having examined the following evidence

- | | | |
|---|---|----------------------------------|
| <input checked="" type="checkbox"/> Video submitted | <input type="checkbox"/> Technical Report | <input type="checkbox"/> Photos |
| <input type="checkbox"/> Time Keeping Report | <input type="checkbox"/> see documents attached | <input type="checkbox"/> Witness |

have considered the following matter and came to the following
DECISION

Drop of 10 positions in the grid for the next race the driver will participate

In accordance with Art. 12.2.3.b ISC, the decision set out above will be suspended in case of an appeal.

FINDINGS

Reason: causing a collision with car #13
Offence: Art. 30.4 Sporting Regulations ADAC Formula 4 2018

announced on **15.04.2018** at **17:10** hours The decision is sent with registered letter and acknowledgement of receipt

Achim LOTH

Carsten Ruscher

Denny Enick

- I herewith confirm having received a copy of the decision and being reminded of my right to appeal.
 I renounce on my right to appeal.

Oschersleben, 15.04.2018

Time: 17:20

ADAC Berlin-Brandenburg e.V.: